

A black and white advertisement for Carron fireplaces. The central focus is a large, ornate, dark-colored fireplace with a fire burning inside. The fireplace has a decorative mantel with a central panel featuring a row of small, repeating motifs. To the left of the fireplace is a brown leather armchair with a white cushion and a brass floor lamp. To the right is another brown leather armchair with a red cushion and a potted plant in a wicker basket. The background wall is light-colored with a framed picture of trees. The Carron logo is in the top right corner.

Carron

SIMPLY SOME OF THE FINEST FIREPLACES AVAILABLE



Specifications

Please note all measurements are approximate and may vary slightly. Please allow a tolerance of plus/minus 10mm. We endeavour to ensure that all colours are as accurate as possible, however we recommend you check with your retailer before placing an order.

Solid Fuels

If using solid fuels please be aware that they will discolour hand burnished. If this is a concern we recommend selecting a graphite black finish. Do not use anthracite or petroleum coke as this will significantly reduce the life of the product. Replacement parts for the Carron fireplace range are available from www.carronspares.co.uk.

Fitting

The fitting of our products must be carried out or supervised by a Hetas qualified solid fuel engineer. We accept no responsibility for any products that are not installed in this way. A list of qualified engineers is available from www.hetas.co.uk

Gas Fires

All our gas fires are manufactured in the UK and comply to all UKCA requirements and British standard BSEN509:2000.

They come complete with flame failure device and oxygen depletion system.

All gas fires must be fitted by a Gas Safe registered installer.

Care of your Fireplace

To keep your fireplace in prime condition, please follow these simple care instructions:

For Hand Burnished Finish:

Keep oiled using a thin coat of a light oil such as 3 in 1 oil. This treatment should be carried out twice a year or as required. Any surface rust should be removed using a fine (grade 00) steel wool and then re-oiled. Avoid exposing the cast iron surface to moisture.

For Graphite Black Finish:

Coat with Liberon iron paste and buff up to enhance the finish of your fireplace. Do not use spray polish or any other method of cleaning than above. Cast iron is a natural material, which is subject to minor imperfections and should be considered part of its characteristics. We reserve the right to amend designs without prior notification. Please consult your retailer prior to placing an order.



Due to the limitation of the printing process/photography, please note that colours may vary from the actual finish.

The Bella Combination

The Bella is a cast iron fireplace in the Art Nouveau style, with stylistic patterning that runs along the frieze and framing. The artistic canopy offers a masterfully textured design with floral patterning.



The Bella in Hand Burnished



The Bella in Graphite Black

The Crocus Combination

The Crocus is a cast iron fireplace in the Art Nouveau style. The impressive design consists of a stemmed flower detail along the length of the frame, wearing either side of a tall, narrow opening and a meticulously detailed canopy with a textured finish.



The Crocus in Hand Burnished



The Crocus in Graphite Black

The Tulip Combination

The Tulip is an understated Art Nouveau cast iron fireplace, with a classically simplistic design that presents a smooth frame with a shaped plain canopy. A classic tulip design sits attractively between the canopy and the shelf.



The Tulip in Hand Burnished

The Tulip in Graphite Black



The Tweed Combination

The Tweed is a Victorian style cast iron fireplace. It's numerous outstanding features include the chain link detail that highlights the fireplace's arch, framed majestically with a sunflower detail.



The Tweed in Graphite Black



The Tweed in Hand Burnished

The Valentine Combination

The Valentine is an Art Nouveau cast iron fireplace, styled with a symmetrical pomegranate design that extends from the centre of the frieze to fill the legs of the framework. The design can be brought to life with the tube lined tiles that sit either side of the fireplace's artistic canopy.



The Valentine in Graphite Black

The Valentine in Hand Burnished



The Verona Combination

The Verona is an Art Nouveau style cast iron tiled fireplace, complete with coloured floral artwork. An accompanying straight-stemmed floral design climbs the length of the cast framing.

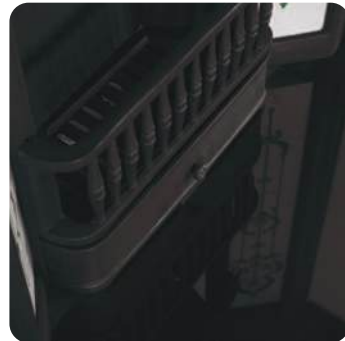

The Verona in Graphite Black



The Victorian Small Combination

The Victorian style cast iron fireplace is perfect in size, design and stature for placement within smaller rooms of the home. It is designed with intricate fruit and urn artwork and a beautiful sunken archway.

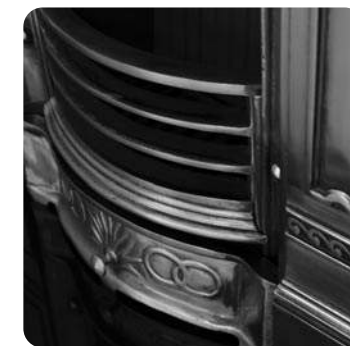

The Victorian Small in Graphite Black

The Victorian Small in Hand Burnished



The Victorian Large Combination

The Victorian style cast iron fireplace is designed with intricate fruit and urn artwork and completed with a beautifully sunken archway, complete with a small but striking canopy.



The Victorian Large in Graphite Black



The Victorian Large in Hand Burnished

The London Plate Insert

The London Plate is an Early Victorian cast iron fireplace insert, with an elegantly simple and wide half-arched opening. The curve of the basket perfectly matches the design of the arch's frame, giving the insert an undoubtedly appealing appearance.



The London Plate in Hand Burnished

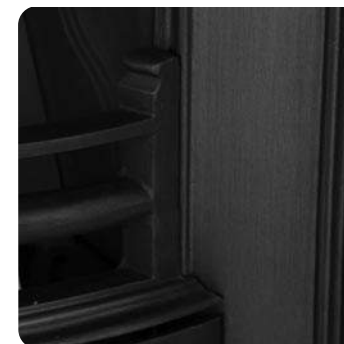

The London Plate in Graphite Black

The Prince Insert

The Prince is an Early Victorian cast iron fireplace insert. The arched opening is decorated at the top with eye catching detail, further emphasized by the classic simplicity of the insert. The basket and ashpan cover blend in perfectly, with curved bars and floral artwork.



The Prince in Graphite Black



The Royal Insert

The Royal is a cast iron fireplace insert in the Georgian style. It is an imposing, straight-edged insert that, with its bold shape and square opening, is sure to immediately command attention.



The Royal in Graphite Black

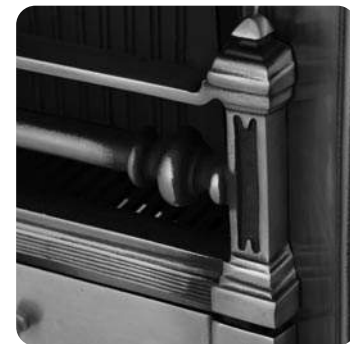

The Royal in Hand Burnished

The Scotia Insert

The Scotia is a cast iron fireplace insert in the Early Victorian style. The opening to The Scotia is surrounded by an ornately decorated double archway.



The Scotia in Graphite Black



The Albert Surround



Finish: Hand Burnished | **Product Code:** RX065
Alternate Finish: Graphite Black | **Product Code:** RX121
Weight: 58KG

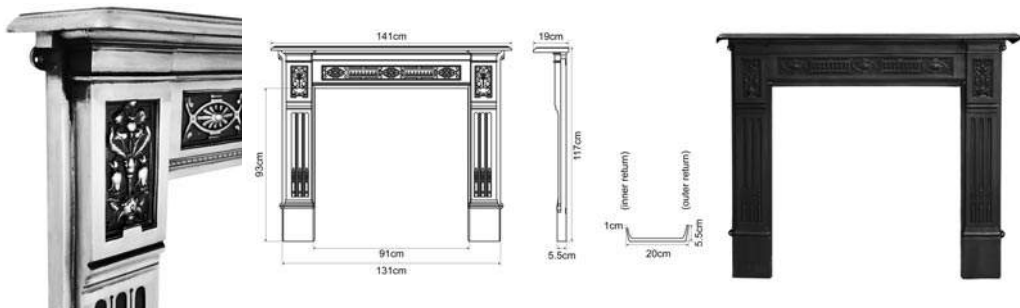

The Alice Surround



Finish: Graphite Black | **Product Code:** RX256
Alternate Finish: Hand Burnished | **Product Code:** RX067
Weight: 55KG

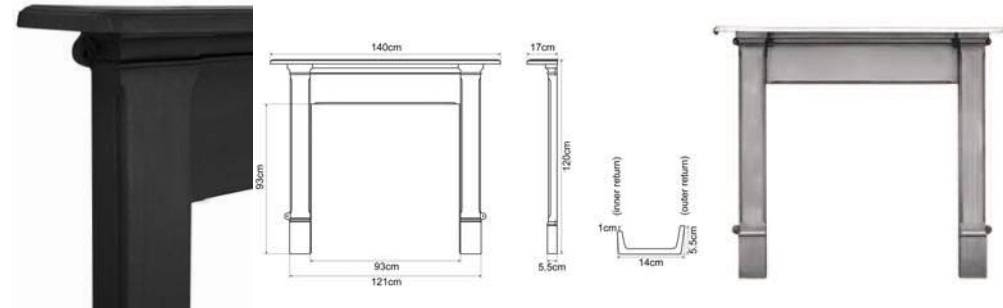

The Belgrave Surround



Finish: Hand Burnished | **Product Code:** TBK152
Alternate Finish: Graphite Black | **Product Code:** TBK153
Weight: 77KG

The Knightsbridge Surround



Finish: Hand Burnished | **Product Code:** RX504
Alternate Finish: Graphite Black | **Product Code:** RX505
Weight: 110KG

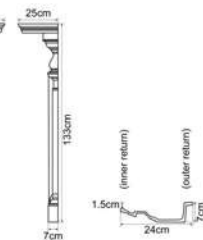
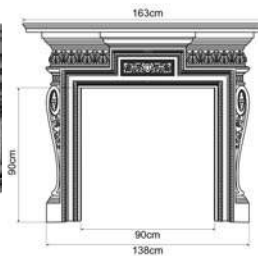
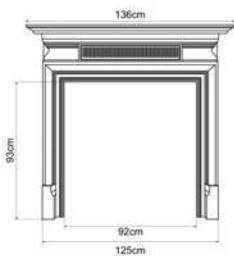

The Regent Surround



Finish: Graphite Black | **Product Code:** RX255
Weight: 56KG

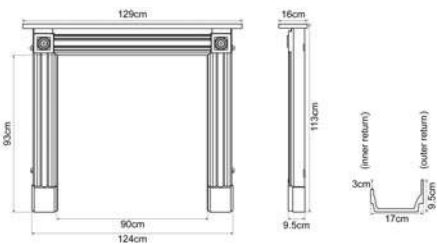

The Somerset Surround



Finish: Hand Burnished | **Product Code:** RX100
Alternate Finish: Graphite Black | **Product Code:** RX101
Weight: 82KG

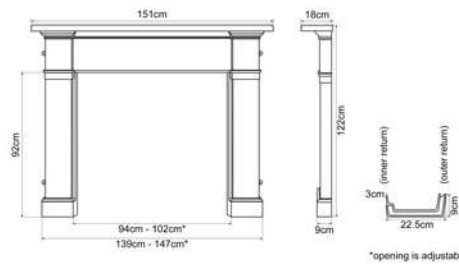

*opening is adjustable

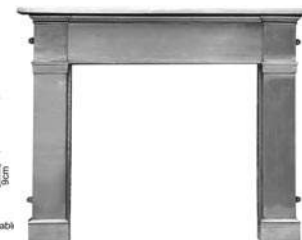

Art Nouveau Surround



Finish: Hand Burnished | **Product Code:** RX520
Alternate Finish: Graphite Black | **Product Code:** RX521
Weight: 80KG

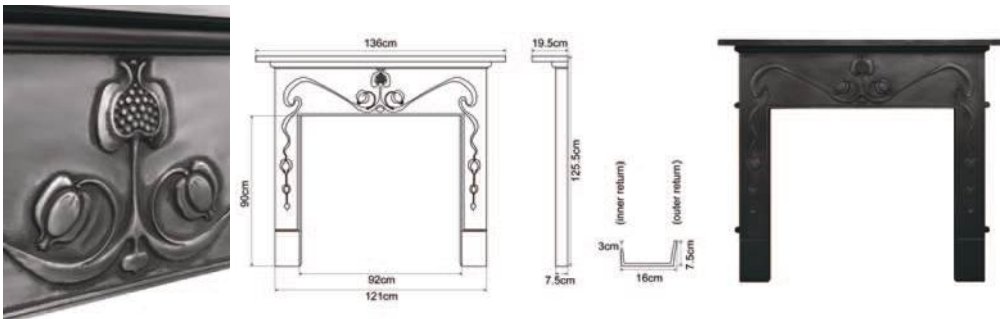

Hearths



Absolute Black Granite (above)

1 Piece Hearths		4 Piece Hearths	
Size (cm)	Code	Size (cm)	Code
92 x 38	GCM281	127 x 38	GCM288
107 x 38	GCM282	132 x 38	GCM289
127 x 38	GCM283	137 x 38	GCM290
132 x 38	GCM284	137 x 46	GCM087
137 x 38	GCM285	152 x 46	GCM089
137 x 46	GCM088	Slip Under	GCM299
152 x 46	GCM286		
Slip Under	GCM299		



Honed Black Granite (above)

1 Piece Hearths		4 Piece Hearths	
Size (cm)	Code	Size (cm)	Code
92 x 38	GCM423	127 x 38	GCM425
107 x 38	GCM424	137 x 46	GCM420
137 x 46	GCM421	152 x 46	GCM422
Slip Under	GCM426	Slip Under	GCM426

GCM427 Honed Black Granite 3 Piece Back Panel 97x97cm (Opening 42x55cm)

Absolute Black Granite



Honed Black Granite



The Berrington Surround



Finish: Unwaxed Oak | **Product Code:** FRM046
Alternate Finish: Unwaxed Pine | **Product Code:** FRM047
Weight: 30KG

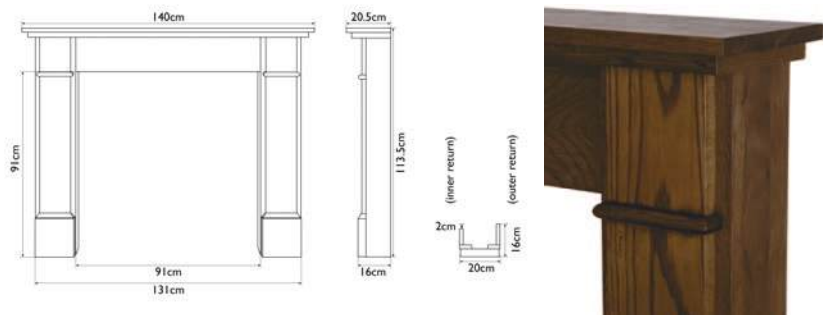

The Corbel Surround



Finish: Unwaxed Pine | **Product Code:** FRM008
Alternate Finish: Unwaxed Oak | **Product Code:** FRM010
Weight: 16KG

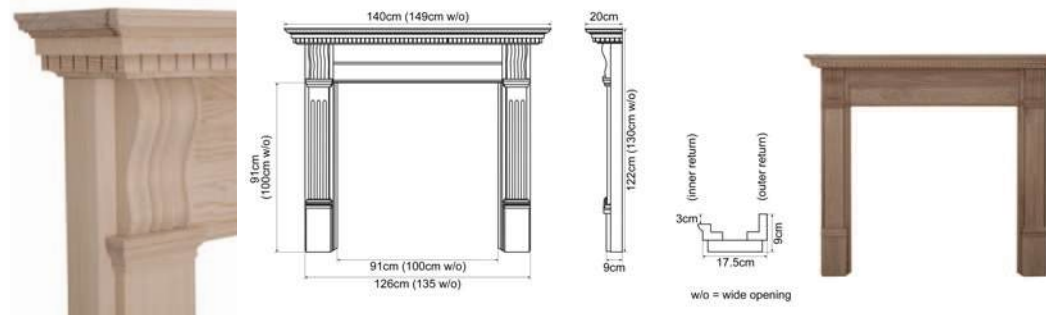

The Derry Surround



Finish: Unwaxed Pine | **Product Code:** FRM005
Alternate Finish: Unwaxed Oak | **Product Code:** FRM035
Weight: 14.1KG

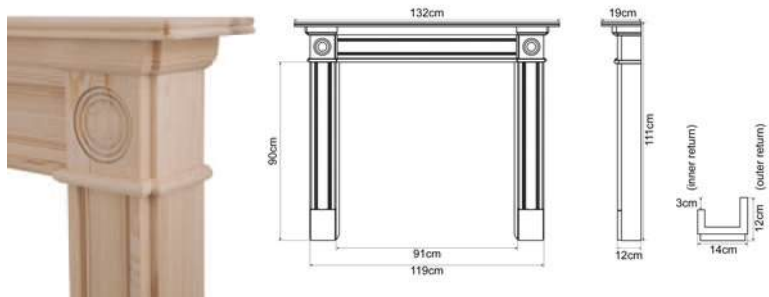

The Edinburgh Surround



Finish: Unwaxed Oak | **Product Code:** FRM036
Alternate Finish: Unwaxed Pine | **Product Code:** FRM014
Weight: 16KG

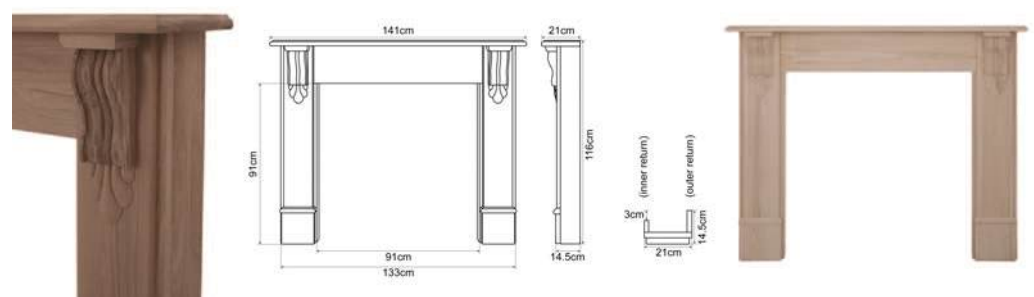

The Grand Surround



Finish: Unwaxed Oak | **Product Code:** FRM048
Alternate Finish: Unwaxed Pine | **Product Code:** FRM049
Weight: 16KG

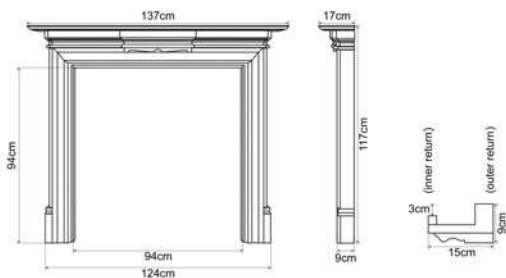

The Hardwick Surround



Finish: Unwaxed Oak | **Product Code:** FRM044
Alternate Finish: Unwaxed Pine | **Product Code:** FRM045
Weight: 28KG

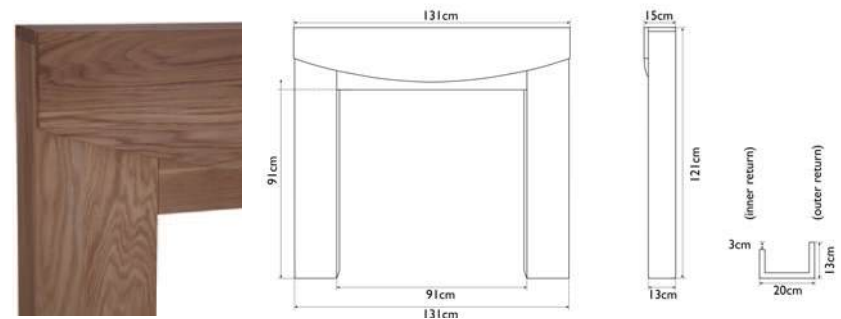

The Kedleston Surround



Finish: Unwaxed Oak | **Product Code:** FRM040
Alternate Finish: Unwaxed Pine | **Product Code:** FRM041
Weight: 28KG

The Nostell Surround



Finish: Unwaxed Oak | **Product Code:** FRM042
Alternate Finish: Unwaxed Pine | **Product Code:** FRM043
Weight: 28KG

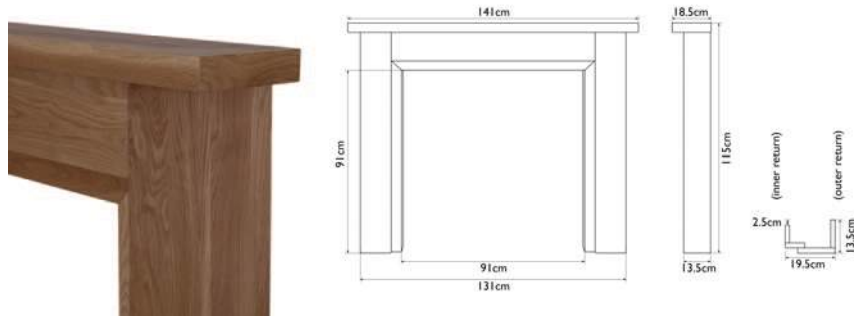

The Wessex Surround

Wax Surround Finishes

Fiddes Supreme Wax Polish



Finish: Unwaxed Pine | **Product Code:** FRM025
Alternate Finish: Unwaxed Oak | **Product Code:** FRM033
Weight: 22KG

Light

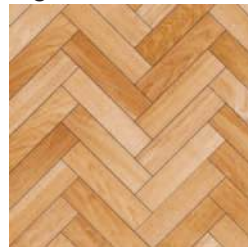

Antique Brown



Rugger Brown

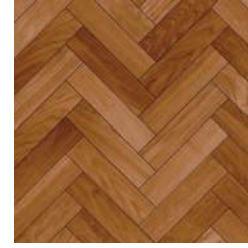

Jacobean



Fiddes Supreme Wax Polish contains a unique, environmentally friendly blend of waxes that naturally enhances the beauty of your wood.





Code:
LGC089



Code:
LGC084



Code:
LGC090



Code:
LGC085



Code:
LGC003



Code:
LGC042



Code:
LGC091



Code:
LGC094



Code:
LGC088



Code:
LGC092



Code:
LGC095



Code:
LGC008



Code:
LGC021



Code:
LGC029



Code:
LGC093



Code:
LGC065



Code:
LGC067



Code:
LGC072



Code:
LGC078



Code:
LGC079



Code:
LGC080



Code:
LGC081

All of our tube lined tiles are hand painted. The crazing that appears in the glaze is a natural characteristic for this type of product.



The Valentine with LGC008



Code: LGC086



Code: LGC018



Code: LGC016



Code: LGC011



Code: LGC012



The Verona with LGC087



Code: LGC014



Code: LGC015



Code: LGC083



Code: LGC087



Code: LGC013



Code: RX080

Cast Iron

Fireplace Diagrams

1. Combination Dimensions

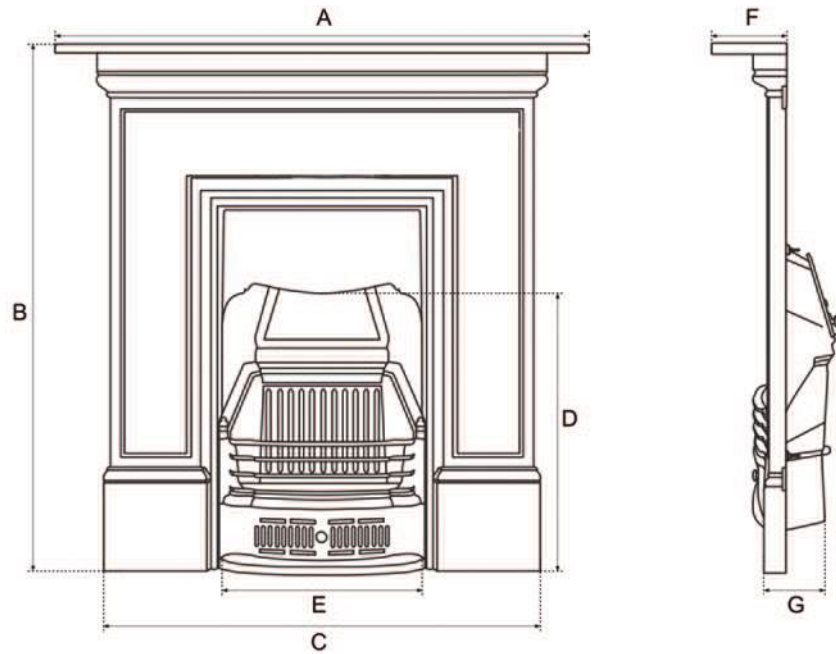

2. Insert Dimensions

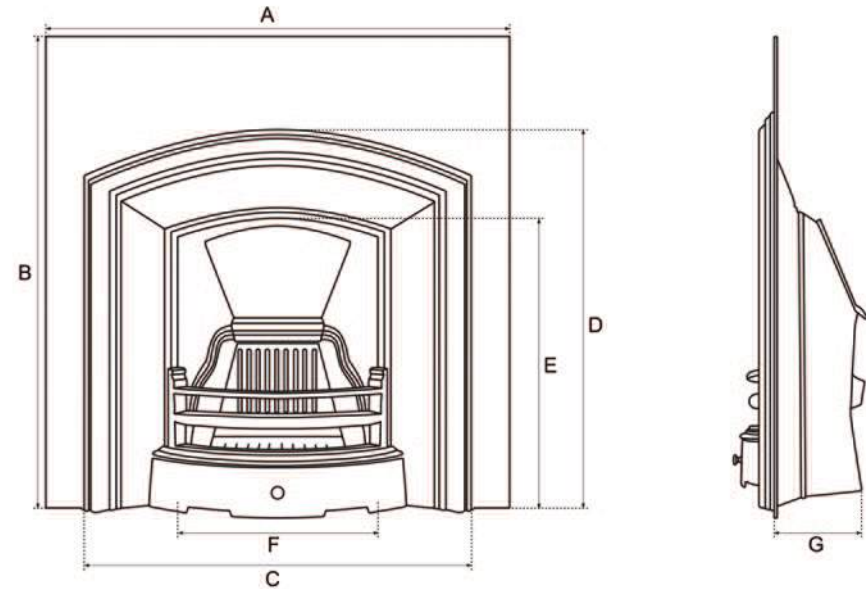

3. Chamber Dimensions

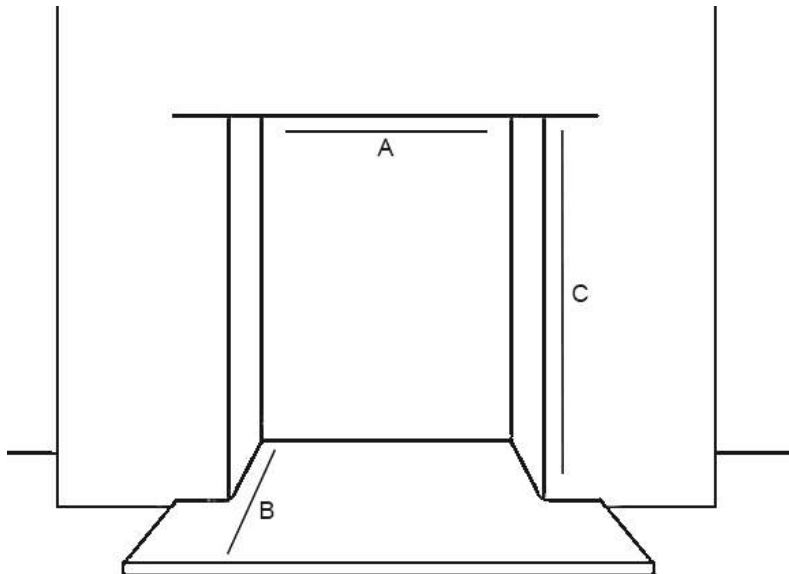

Important Information

All dimensions shown should only be used as a guide.

All products (except The Valentine Combination) are suitable for burning solid fuel. The grate is a consumable component to your fire and will require a replacement every so often, dependent on use.

Ensure all ash is thoroughly cleared to avoid build up beneath the grate.

SIMPLY SOME OF THE FINEST
FIREPLACES AVAILABLE



For your nearest stockist: Telephone: 01400 263319 or Visit: www.carronheating.co.uk